

PERMASEAL® PLUG VALVES TECHNICAL SPECIFICATIONS

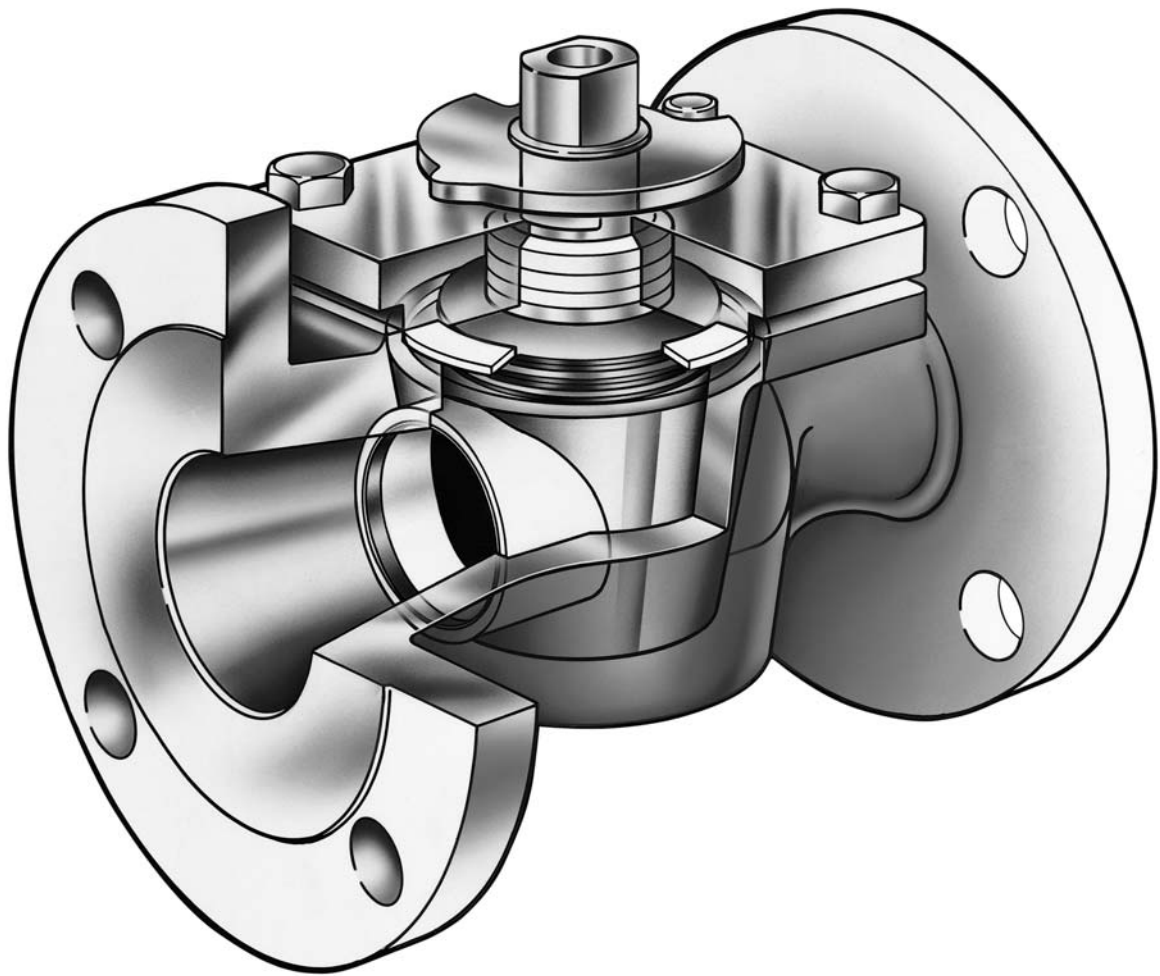

Materials of Construction

Body & Cover	Carbon Steel (CS) ASTM A216, Grade WCB -20–800°F (-28–425°C)	316L Stainless Steel (S2), ASTM A351, Grade CF3M -425–850°F (-253–455°C)	Alloy 20 (AA) ASTM A351 Grade CN7M -425–300°F (-253–150°C)	Monel (ML) ASTM A494, Grade M35-1 -425–850°F (-253–455°C)	Hastelloy C (HC) ASTM A494 CW2M -425–1000°F (-253– 540°C)
Plug	316L Stainless Steel ASTM A351, Grade CF3M	316L Stainless Steel ASTM A351, Grade CF3M	Alloy 20 ASTM A351, Grade CN7M	Monel ASTM A494, Grade M35-1	Hastelloy C ASTM A494 CW2M
Cover Screws	Carbon Steel	304 Strain Hardened Stainless Steel	304 Strain Hardened Stainless Steel	304 Strain Hardened Stainless Steel	304 Strain Hardened Stainless Steel
Belleville Washers	316L Stainless Steel	316L Stainless Steel	Alloy 20	Inconel X-750	Hastelloy C
Seat Insert Ring	316L Stainless Steel	316L Stainless Steel	Alloy 20	Monel	Hastelloy C
Stop/Travel Indicator	Zinc Plated Steel	Zinc Plated Steel	Zinc Plated Steel	Zinc Plated Steel	Zinc Plated Steel
Seat Options:					
PTFE and Reinforced PTFE Seats:					
Gasket	Reinforced PTFE	Reinforced PTFE	Reinforced PTFE	Reinforced PTFE	Reinforced PTFE
Stem Seal	PTFE	PTFE	PTFE	PTFE	PTFE
Thrust Ring	316 Stainless Steel 6" (150mm)	316 Stainless Steel 6" (150mm)	Alloy 20 6" (150mm)	Monel 6" (150mm)	Hastelloy C 6" (150mm)
UHMW Polyethylene Seat:					
Gasket	UHMW Polyethylene	UHMW Polyethylene	UHMW Polyethylene	UHMW Polyethylene	UHMW Polyethylene
Stem Seal	UHMW Polyethylene	UHMW Polyethylene	UHMW Polyethylene	UHMW Polyethylene	UHMW Polyethylene
Thrust Ring	316 Stainless Steel 1-6" (25-150mm)	316 Stainless Steel 1-6" (25-150mm)	316 Stainless Steel 1-6" (25-150mm)	Monel 1-6" (25-150mm)	Hastelloy C 1-6" (25-150mm)
Carbon Graphite Seat:					
Gasket	Compressed Graphite Fiber	Compressed Graphite Fiber	Compressed Graphite Fiber	Compressed Graphite Fiber	Compressed Graphite Fiber
Stem Seal	Graphoil	Graphoil	Graphoil	Graphoil	Graphoil
Thrust Ring	316 Stainless Steel 1-6" (25-150mm)	316 Stainless Steel 1-6" (25-150mm)	Alloy 20 1-6" (25-150mm)	Monel 1-6" (25-150mm)	Hastelloy C 1-6" (25-150mm)

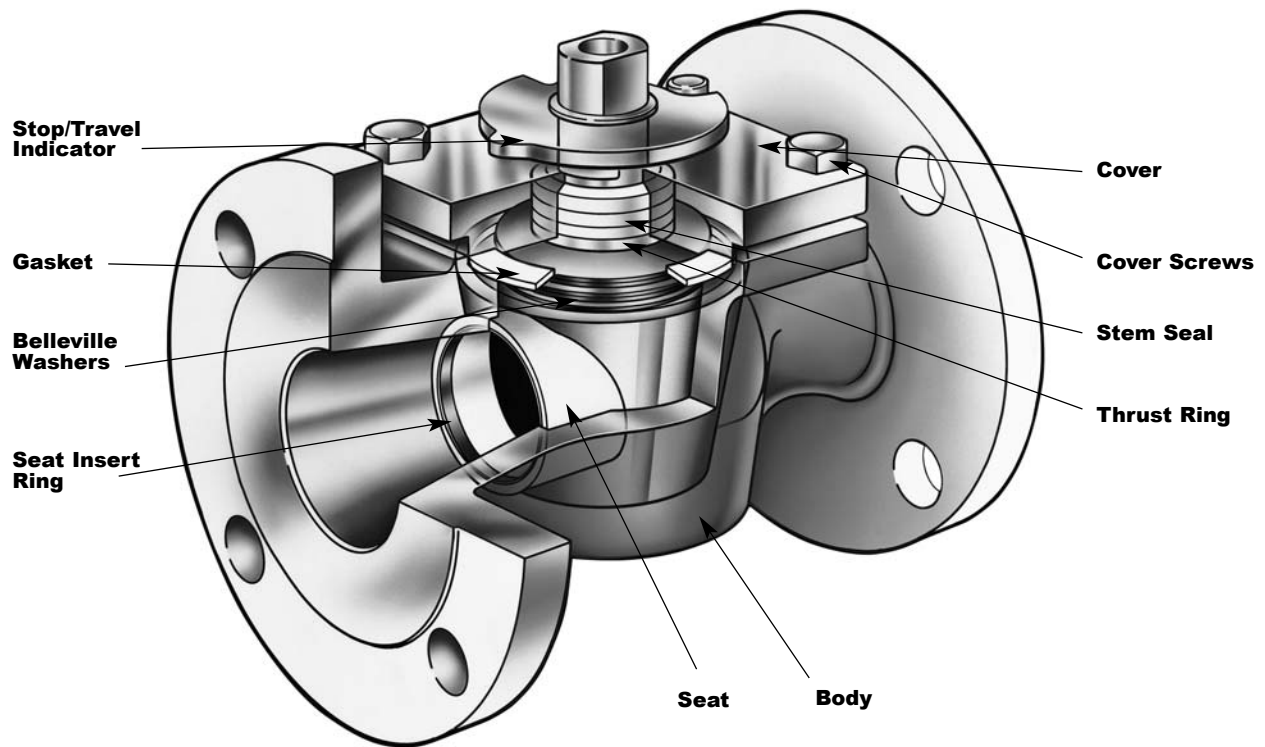

Valve Selection

Shutoff Capabilities

Carbon graphite seat	Class IV
PTFE, reinforced PTFE and UHMW polyethylene seats	Class VI

Pressure vs. Temperature Capability .5–3" (15–80mm)

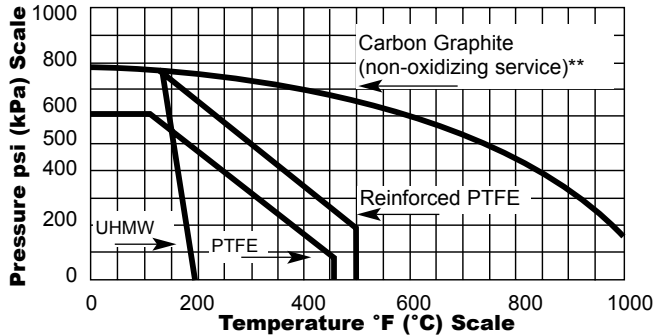

**For oxidizing service, contact factory.
For larger sizes, contact factory.

Maximum Pressure at Ambient Temperature (CWP)

Body Material	ANSI 150 psi/kPa	ANSI 300 psi/kPa
Carbon Steel	285 1960	740 5100
Stainless Steel	275 1890	720 4960
Alloy 20	230 1580	600 4130
Monel	230 1580	600 4130
Hastelloy C	285 1960	740 5100

Note: Consult ANSI standards for pressure/temperature limits of body. Use of carbon steel is permissible but not recommended for prolonged usage above 800°F (425°C). Temperature beyond 850°F (455°C) may reduce corrosion resistance of stainless steel. For Alloy 20 pressure vs. temperature capabilities, contact factory.

Cv/Kv Values

Valve Size	2-Way	3-Way		
		W Plug		X, Y, Z* and T* Plugs
		Ports A to B	Ports A to C and B to C	Ports A to C and B to C
.5" 15mm	13	4.6	2.1	4.2
	11	4.0	1.8	3.6
.75" 20mm	13	4.6	2.1	4.2
	11	4.0	1.8	3.6
1" 25mm	36	14.8	8.0	19
	31	12.8	6.9	16.4
1.5" 40mm	90	28.2	12.0	34.0
	78	24.4	10.4	29.4
2" 50mm	130	36.0	22.0	37
	112	31.1	19.0	32
2.5" 65mm	180	63.0	35.0	75
	156	54.5	30.3	65
3" 80mm	180	63.0	35.0	75
	156	54.5	30.3	65
4" 100mm	260	92	52	125
	225	79.6	45	108.1
6" 150mm	650	154.0	200	200
	562	133.2	173	173

* Cv/Kv values for the A to B ports on the Z3 and T2 plugs are the same as shown for 2-way plugs.

Cv = Flow in GPM of water at 1 psi pressure drop.

Kv = Flow in m³/hr. of water at 100 kPa pressure drop.

Seats

Standard

PTFE (polytetrafluoroethylene) possesses almost universal chemical inertness and is effected only by molten alkali metals, fluorine and chlorine trifluoride at elevated temperatures. Temperature range is -50–450°F (-45–232°C).

Options

UHMW (ultra high molecular weight polyethylene) has excellent resistance to radiation and abrasive applications. It is resistant to most chemicals except oxidizing acids and some hydrocarbon solvents. Temperature range is -50–175°F (-45–80°C).

Reinforced PTFE contains a filler to enhance the mechanical properties and allow higher pressure and temperature capabilities. Seat does not provide gas tight shutoff at ambient temperatures. Temperature range is -50–500°F (-45–260°C).

Carbon Graphite is a high temperature, corrosion resistant material. It does not provide drip-tight shutoff. Temperature range is -50–1000°F (-45–540°C). (Consult ANSI standards for pressure/temperature limits of body.)

Valve Weights

2-Way Basic Valve Does not include actuator

Valve Size	Buttweld, Socket and Threaded lbs/kg	Flanged	
		Class 150	Class 300
.5" 15mm	2 1	3.5 1.5	4.5 2
.75" 20mm	2 1	5 2.5	6 3
1" 25mm	6 3	10 4.5	14 6.5
1.5" 40mm	8 4	14 6.5	18 8
2" 50mm	12 5.5	18 8	24 11
2.5-3" 65-80mm	19 9	34 15	49 22
4" 100mm	30 14	54 24.5	73 33
6" 150mm	88 40	122 55	168 76

Note: Weights are approximate and do not include crating.

3-Way Basic Valve Does not include actuator

Valve Size	Buttweld, Socket and Threaded lbs/kg	Flanged	
		Class 150	Class 300
.5" 15mm	3 1.5	4.5 2	5.5 2.5
.75" 20mm	3 1.5	6 3	7 3.2
1" 25mm	7 3	12 5.5	18 8
1.5" 40mm	9 4	20 10	24 11
2" 50mm	13 6	25 11	32 15
2.5-3" 65-80mm	20 10	44 20	64 29
4" 100mm	32 15	66 30	96 44
6" 150mm	92 42	139 63	208 94

Actuators

Lever (LV)	
.5-2" (15-50mm)	= 1.5 lbs (1 kg)
2.5-4" (65-100mm)	= 2 lbs (1.9 kg)

Refer to specific actuator bulletins for weights of handwheels and cylinder actuators.

Applicable Standards

Southern Manufacturing Group Permaseal Plug Valve has been designed and/or tested to meet the following standards:

ANSI B1.20.1	Conforms to pipe thread requirements.
ANSI B16.10	Conforms to face-to-face dimension requirements.
ANSI B16.25	Buttwelding Ends – Conforms to requirements of Schedule 40 pipe, without backing ring.
ANSI B16.34	Valves, Flanged and Buttwelding Ends – Conforms to wall thickness requirements and pressure-temperature ratings.
ANSI B16.5	Pipe Flanges and Flanged Fittings – Conforms to flange thickness and drilling requirements.
ANSI B16.42	Ductile Iron Pipe Flanges and Flanged Fittings – Conforms to flange drilling requirements.
MSS-SP-84	Steel Valves, Socket Welding and Threaded Ends – Conforms to socket weld end requirements.
MSS-SP-25	Conforms to related marking requirements.
MSS-SP-61	Conforms to production testing requirements.
U.S. Coast Guard	Approved for Category B service.
British Standard BS 4504	Flanges are drilled to standard PN10, PN16, PN25 and PN40.

3-Way Plug and Flow Arrangements

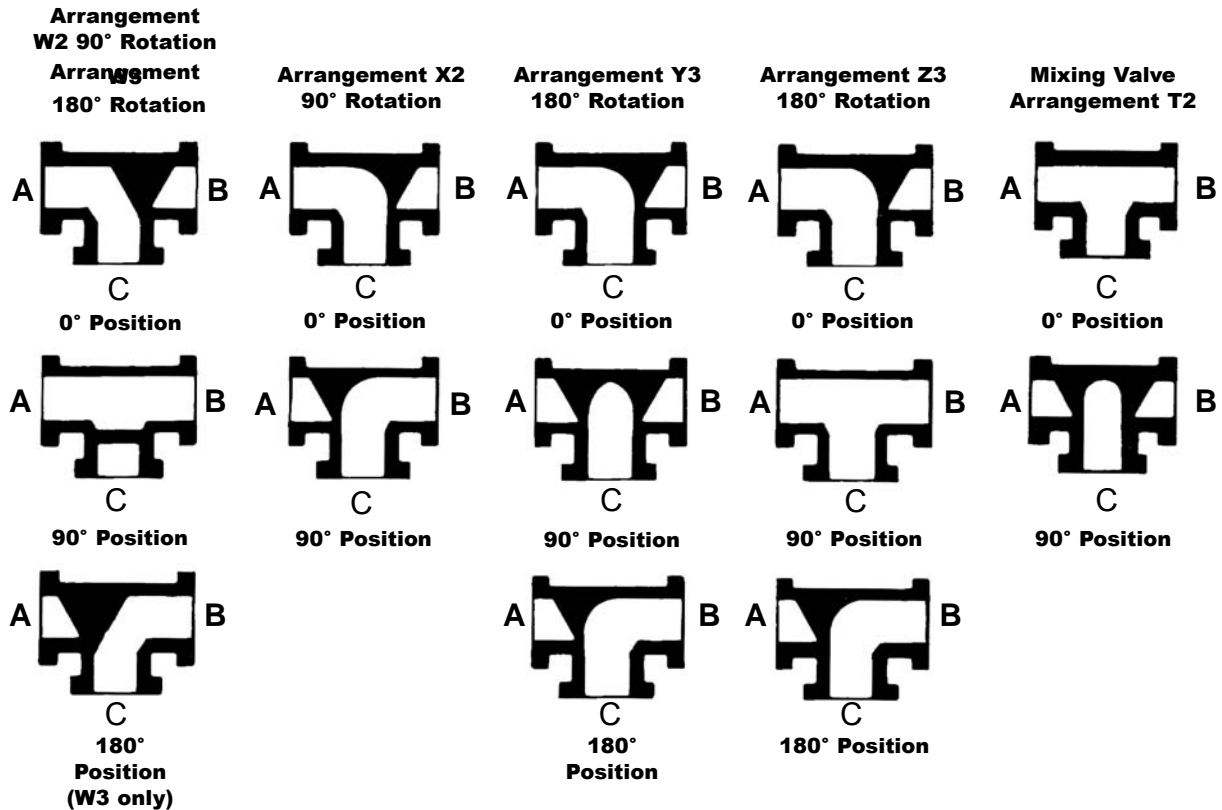

Note: Three-way plugs are recommended for diverting applications, with pressure at port C. Mixing applications with pressure at ports A and B may result in leakage.

The above valve plug configurations will mix A and B equally into C. The amount of mixing can be controlled by the position of the plug.

Actuators

Lever Actuators

Valve sizes .5–4" (15–100mm) are available with lever actuators. They are carbon steel on .5" (15mm) and .75" (20mm) valves and cast iron on 1–4" (25–100mm). To order, add LV to basic valve identification.

Ordering Example:

PPS,3,F1,CS,2W,T*LV

Handwheel Actuators

For information on manual actuators, refer to bulletin 72.00-1 and 72.00-2.

Compak Cylinder Actuators

Compak actuators are a versatile rack-and-pinion design and are available as double-acting or spring-return units. The compact, modular design allows the actuator to be mounted for a low profile assembly. Compak actuators are matched to each valve's torque requirements to ensure that the most economical valve and actuator package is specified. For information on Compak actuators, refer to bulletin 71.00-1 and 71.00-2.

Electric Motors

Electric motors offer reliable and economical valve operation. When ordering electric motor actuators, specify: electrical characteristics, flowing media, pressure drop, speed of operation and actuator accessories or controls required. Contact Southern Manufacturing Group for additional information.

Ordering

To order, simply complete the valve order code from information shown. An ordering example is shown for your reference.

Valve Style	
Give valve style code as follows:	
PPS	= Permaseal Plug Valve

Valve Size			
Give valve size code as follows:			
.5	= .5" (15mm)	2.5	= 2.5" (65mm)
.75	= .75" (20mm)	3	= 3" (80mm)
1	= 1" (25mm)	4	= 4" (100mm)
1.5	= 1.5" (40mm)	6	= 6" (150mm)
2	= 2" (50mm)		

End Connection	
Give end connection code as follows:	
Class 150	
F1	= Flanged, ANSI Class 150
F110	= Flanged, Class 150 DIN 10 or BS4504/10
F116	= Flanged, Class 150 DIN 16 or BS4504/16
T1	= Threaded, ANSI Class 150 .5-2" (15-50mm)
BW11	= Butt Weld, Class 150 (Schedule 10 Pipe)
BW14	= Butt Weld, Class 150 (Schedule 40 Pipe)
SW1	= Socket Weld, Class 150 .5-2" (15-50mm)
Class 300	
F2	= Flanged, ANSI Class 300
F225	= Flanged, Class 300, DIN 25 or BS4504/25
F240	= Flanged, ANSI Class 300 DIN 40 or BS4504/40
T2	= Threaded, Class .5-2" (15-50mm)
BW24	= But Weld, Class 300 (Schedule 40 Pipe)
BW28	= Butt Weld, Class 300 (Schedule 80 Pipe)
SW2	= Socket Weld, Class 300 .5-2" (15-50mm)
JIS end connections and butt weld for other pipe schedules are available on application.	

Body Material	
Give body material code as follows:	
CS	= Carbon Steel, 316 Stainless Steel Plug
S2	= 316L Stainless Steel, 316 Stainless Steel Plug
AA	= Alloy 20, Alloy 20 Plug
HC	= Hastelloy "C", Hastelloy "C" Plug
ML	= Monel, Monel Plug

Body and Plug Combination	
Give combination code as follows:	
2W	= 2-Way
W2	= 3-Way, W2 Position
X2	= 3-Way, X2 Position
T2	= 3-Way, T2 Position
W3	= 3-Way, W3 Position*
Y3	= 3-Way, Y3 Position*
Z3	= 3-Way, Z3 Position*
*Note: 3 Position Plug combinations are available with lever and special actuators only.	

Seat Seal Material	
Give seat seal material code as follows:	
T	= PTFE (1)
TF	= Reinforced PTFE (1)
UHMW	= UHMW Polyethylene (2)
G1	= Carbon Graphite (3)
Note: 1. Not available on 6" (150mm) above 300 PSI. 2. UHMW includes UHMW packing and gaskets. 3. .5" and .75" (15 and 20mm) not available with G1 seats.	

Optional Construction	
Give option code as follows:	
FJ	= Full Jacket 2-Way Flanged .75-2" (20-50mm) and 3-6" (80-150mm)
PJ	= Partial Jacket 2-Way Flanged
Note: Bolt-on jackets must be ordered as a separate item. Enter ACC*BJ2W followed by the flanged end style code (F1 or F2) then a dash and the appropriate valve size.	

Ordering Example:
PPS,2,F1,S2,2W,T*actuator

Dimensions Basic Valve, 2-Way

Flanged

.5 and .75" (15 and 20mm)

1-6" (25-150mm)

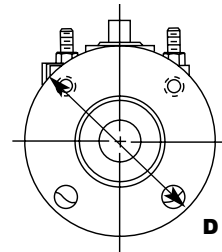
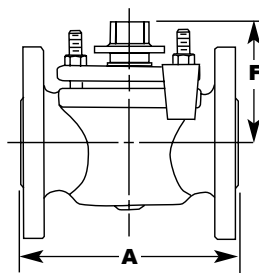
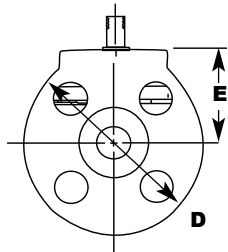
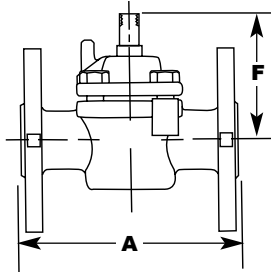

Butt Weld, Socket Weld, Threaded

.5 and .75" (15 and 20mm)

1-6" (25-150mm)

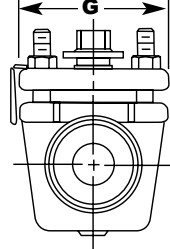
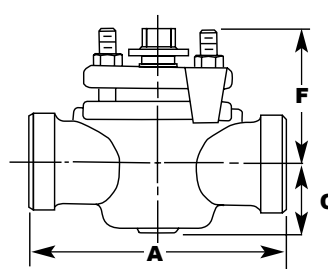
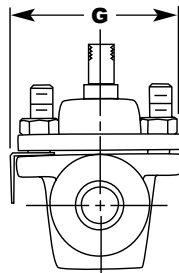
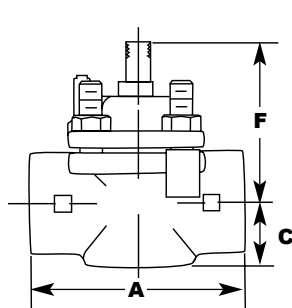

2-Way Valves

Valve Size	Dimensions									
	A			C	D		E		F	G
	Butt Weld, Socket Weld, Threaded	Flanged		Butt Weld, Socket Weld, Threaded	Flanged		Flanged		Flanged, Socket Weld, Threaded	Butt Weld, Socket Weld, Threaded
	ANSI 150 and 300	ANSI 150	ANSI 300	ANSI 150 and 300	ANSI 150	ANSI 300	ANSI 150	ANSI 300	ANSI 150 and 300	ANSI 150 and 300
.5" 15mm	3.25 83	4.25 108	5.50 140	.94 24	3.50 89	3.75 95	1.75 44	2.00 51	2.41 61	2.50 64
.75" 20mm	3.25 83	4.62 118	6.00 152	.94 24	3.88 98	4.62 118	1.94 49	2.78 71	2.41 61	2.50 64
1" 25mm	5.50 140	5.50 140	6.50 165	1.62 41	4.25 108	4.88 124	-	-	3.16 80	3.50 89
1.5" 40mm	6.50 165	6.50 165	7.50 191	1.75 44	5.00 127	6.12 155	-	-	3.03 77	3.62 92
2" 50mm	7.00 178	7.00 178	8.50 216	2.00 51	6.00 152	6.50 165	-	-	3.41 87	4.00 102
2.5" 65mm	-	8.00 203	9.50 241	-	7.00 178	7.50 191	-	-	3.62 92	-
3" 80mm	8.00 203	8.00 203	11.12 282	2.31 59	7.50 191	8.25 210	-	-	3.62" 92	4.94 126
4" 100mm	9.00 229	9.00 229	12.00 305	2.60 67	9.00 229	10.00 254	-	-	3.88" 99	5.75 146
6" 150mm	10.50 267	10.50 267	15.88 403	3.91 99	11.00 279	12.50 318	-	-	5.38" 137	8.12 206

Inches
Millimeters

**Butt Weld and Flanged only.

Note: Dimensions are subject to change without notice. Request certified drawings.

Basic Valve, 3-Way

Flanged

.5 and .75" (15 and 20mm)

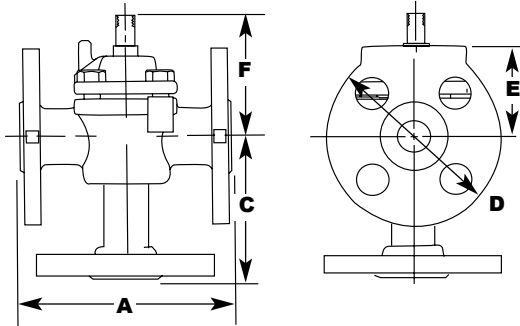

1-6" (25-150mm)

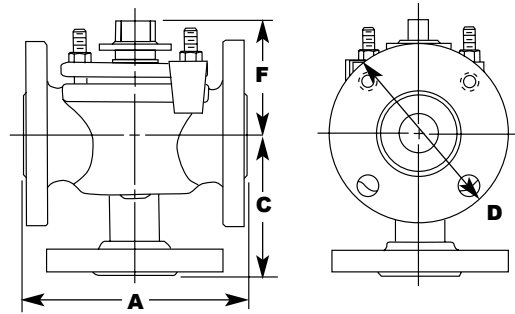

Butt Weld, Socket Weld, Threaded

.5 and .75" (15 and 20mm)

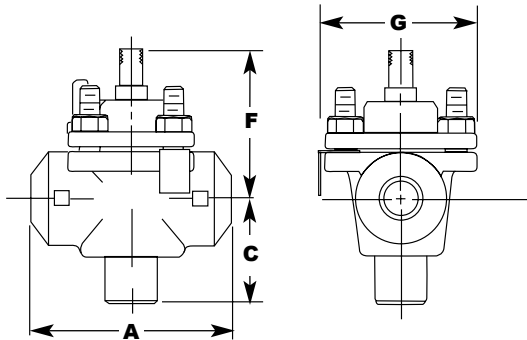

1-6" (25-150mm)

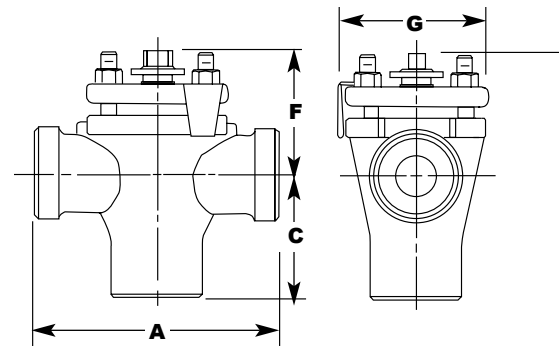

3-Way Valves

Valve Size	Dimensions												
	A			C				D		E		F	G
	Butt Weld, Socket Weld, Threaded	Flanged		Butt Weld, Socket Weld, Threaded	Flanged		Flanged		Flanged		Flanged, Socket Weld, Threaded	Butt Weld, Socket Weld, Threaded	
	ANSI 150 and 300	ANSI 150	ANSI 300	ANSI 150 and 300	ANSI 150	ANSI 300	ANSI 150	ANSI 300	ANSI 150	ANSI 300	ANSI 150 and 300	ANSI 150 and 300	
.5" 15mm	3.25 83	4.25 108	5.50 140	1.69 43	2.75 69.8	2.88 73.2	3.50 89	3.75 95	1.75 44	2.00 51	2.41 61	2.50 64	
.75" 20mm	3.25 83	4.62 118	6.00 152	1.75 44	2.94 74.6	3.00 76.2	3.88 98	4.62 118	1.94 49	2.78 71	2.41 61	2.50 64	
1" 25mm	5.50 140	5.50 140	6.50 165	2.62 67	3.50 88.9	3.75 95.2	4.25 108	4.88 124	-	-	3.16 80	3.50 89	
1.5" 40mm	6.50 165	6.50 165	7.50 191	3.06 78	4.12 104.6	4.38 111.3	5.00 127	6.12 155	-	-	3.03 77	3.62 92	
2" 50mm	7.00 178	7.00 178	8.50 216	3.38 86	4.50 114.3	4.75 120.6	6.00 152	6.50 165	-	-	3.41 87	4.00 102	
2.5" 65mm	-	8.00 203	9.50 241	-	5.12 130.0	5.56 141.2	7.00 178	7.50 191	-	-	3.62 92	-	
3" 80mm	8.00 203	8.00 203	11.12 282	4.00 102	5.12 130.0	5.56 141.2	7.50 191	8.25 210	-	-	3.62** 92	4.94 126	
4" 100mm	9.00 229	9.00 229	12.00 305	4.50 114	6.0 152.4	6.75 171.4	9.00 229	10.00 254	-	-	3.88** 99	5.75 146	
6" 150mm	10.50 267	10.50 267	15.88 403	6.26 160	7.50 190.5	8.50 215.9	11.00 279	12.50 318	-	-	5.38** 137	8.12 206	

Inches
Millimeters

**Butt Weld and Flanged only.

Lever

Flanged

.5 and .75" (15 and 20mm)

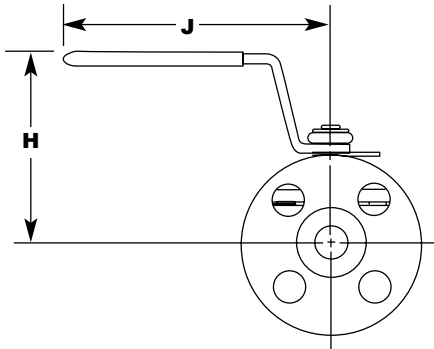

1-4" (25-100mm)

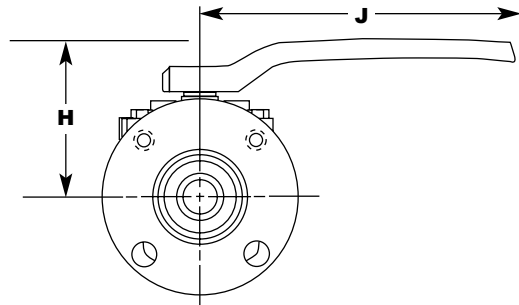

Butt Weld, Socket Weld, Threaded

.5 and .75" (15 and 20mm)

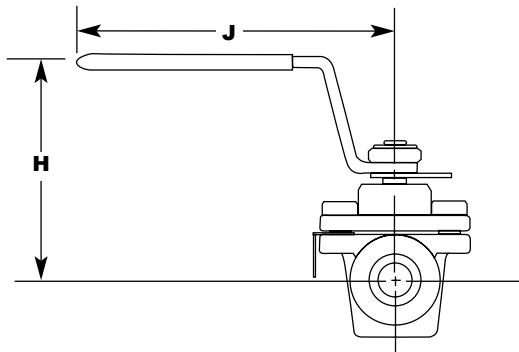

1-4" (25-100mm)

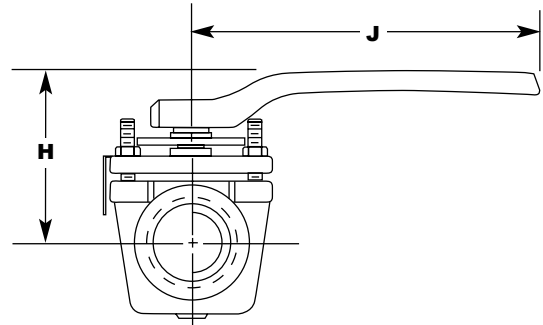

Lever

Valve Size	Dimensions	
	Butt Weld, Socket Weld, Threaded and Flanged ANSI 150 and 300	
	H	J
.5" 15mm	3.69 94	5.12 130
.75" 20mm	3.69 94	5.12 130
1" 25mm	4.25 108	9.00 229
1.5" 40mm	4.56 116	9.00 229
2" 50mm	4.62 117	9.00 229
2.5" 65mm	5.50* 140	12.19* 310
3" 80mm	5.50** 140	12.19** 310
4" 100mm	5.75** 146	12.19* 310

**Butt weld and flanged only.

*Flanged only.

